



FREE

Penguin Readers

Teacher's Guide

to Using Film and TV

Carolyn Walker



The **best** choice of Graded Readers

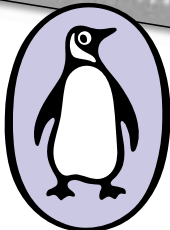
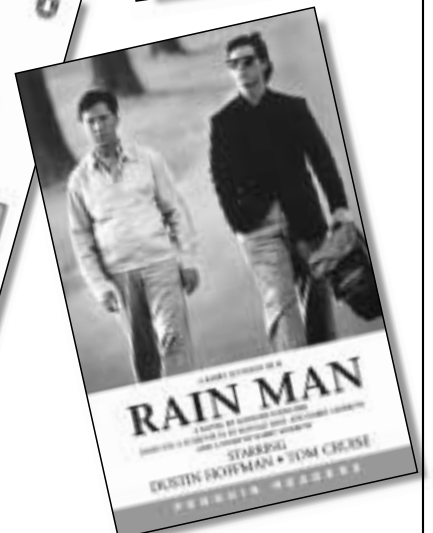
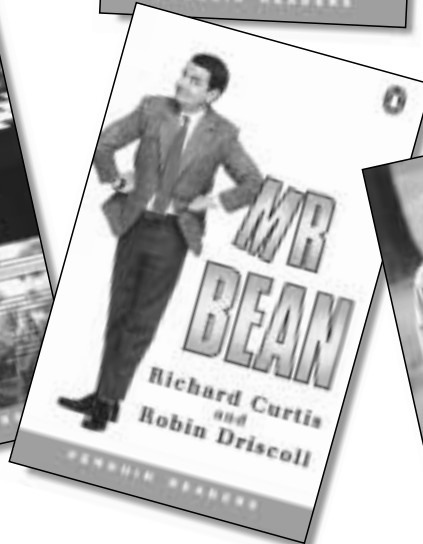
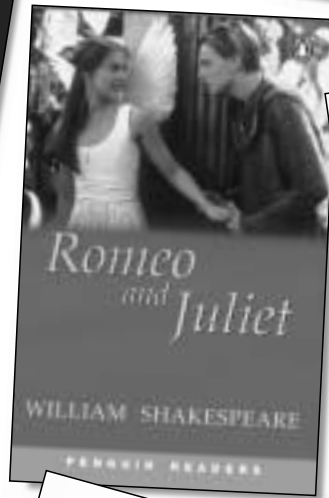
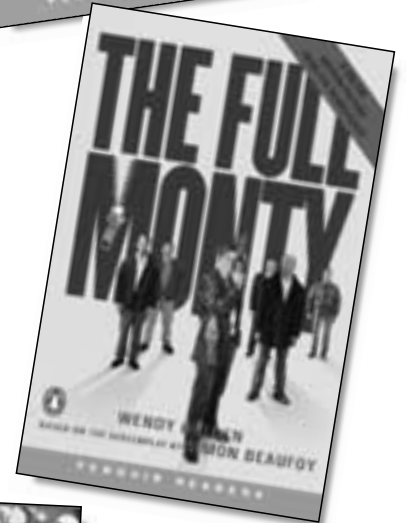
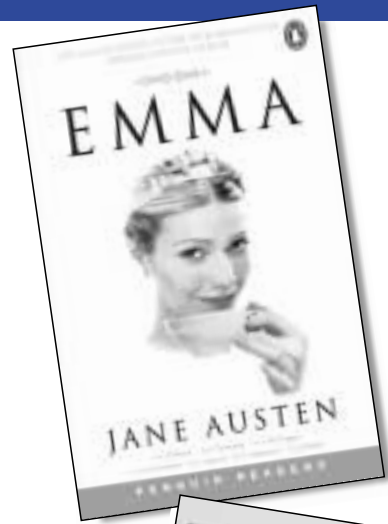

www.penguinreaders.com

Contents

Introduction	2
<hr/>	
Graded Readers: some preliminary comments	2
<hr/>	
Video as a classroom medium	2
<hr/>	
Video films and Graded Readers	3
<hr/>	
Teaching reading and the use of video films	3
<hr/>	
Technical points when using video films in class	4
<hr/>	
Choosing and developing video materials for Graded Readers	4
<hr/>	
Using video clips with a class Reader: some activities and suggestions	
<hr/>	
<i>Before reading the book or sections of the book</i>	5
Using video to preview the story	5
Using video for vocabulary teaching	7
Comprehension of the video clip	7
<hr/>	
<i>After reading short sections of the book</i>	9
Inferring	9
Same or different?	10
Further suggestions for homework	10
<hr/>	
<i>After reading the book</i>	11
Using clips	11
Using the whole film	11
Projects	12
<hr/>	
Bibliography	12
<hr/>	
Photocopiable Student's Worksheets	
1	Establishing the characters
2	Previewing a part of the book
3	Getting the picture
4	The starting point
5	Thinking about character
6	From book to film
7	Conversation: same or different?
8	Timelines: same or different?
9	Remembering the characters
10	Favourite scenes
11	Book compared to film
12	A film review
<hr/>	



Introduction

A large number of the books in the Penguin Readers series have been made into a feature film or TV series or are written from the screenplay of a feature film or TV series. These films are widely available on video. Why shouldn't teachers make use of this very valuable resource in the classroom? This book is intended to provide teachers with some ideas for using video films in conjunction with Graded Readers.

Graded Readers: some preliminary comments

Graded Readers have a very important role to play in the learning of English. Research has shown that reading a lot of interesting material at the appropriate level of language will help students to:

- improve their reading skills and become faster and more fluent readers
- improve their knowledge of grammar and vocabulary
- improve their spelling
- improve other language skills including writing, speaking and listening
- improve their general knowledge
- improve their confidence in reading and their attitude to reading for pleasure

Graded Readers are ideal for extensive reading because most series include books for every level of language competence, from beginner to advanced.

There are three main ways in which a Graded Reader can be used:

- *As a class Reader:* the teacher of a class, or the teacher together with the students, chooses a book at the right level for the class, and everyone has a copy of the book to read. Students can do the reading at home or in class, individually or as shared or group reading. Exercises and activities for class work can be based on the class Reader.
- *In a class library:* a selection of books at the right level for a class is assembled. On a regular basis, each student chooses a book to read. Students read their books in class in a 'quiet reading session', or they read the books at home for homework. The teacher may wish to see each student individually to discuss the book they are reading. There may also be activity sheets and exercises to do.
- *As part of a school library.* The school may have its own library, or a reading section which is part of a larger self-access centre. Here each student withdraws a book appropriate for his or her level whenever they wish. The book may or may not have an accompanying activity sheet. Teachers may ask students to write 'reading diaries' so that a record of the reading is kept.

Detailed suggestions and advice on using Graded Readers can be found in the *Penguin Readers Teacher's Guide to Using Graded Readers* (1998).

Video as a classroom medium

Teachers have been using video in language teaching for many years. The combination of sound and vision is a particularly exciting and dynamic way of exposing learners to language. Video is *intrinsically* motivating: the screen captures our attention in a way quite unlike other media.

Contextualized information

Video offers learners an opportunity to experience spoken language in action in the next best way to being in the language community itself. Most of the features of a real communicative situation are present: as well as the soundtrack, there is also a wealth of visual information which accompanies the language. For example, with a video, learners can see what the setting of the story is and what the characters look like, which both provides contextual information and aids comprehension. Learners can see clues in the physical setting as to the formality or informality of the situation, which will be important for the type of vocabulary, structures, stress, rhythm and intonation they will hear.

In addition, learners can see how people move as they speak, how their bodies move in time with the rhythm of their speech, what their arm gestures and facial expressions are, and the general 'set' of the mouth and jaw in the articulation of speech sounds. They can see how eye contact plays a role in spoken communication, along with other non-linguistic ways in which people relate to each other. All of these aspects will provide learners with a wealth of linguistic, paralinguistic and cross-cultural information which will enable comparison with their own language and culture.

Visual aid

An important point, already hinted at above, is that video can act as a visual aid for language learning. In language teaching we make much use of photographs and other types of still picture to help teach and to provide stimuli for the practice of language. Using video films for this purpose gives an added dimension – namely that of time and movement. A sequence from a video film, whether with sound or not, can depict narrative in a way that is quite impossible with still pictures. Thus, the visual content of a video film can be exploited to good purpose, even where the language may sometimes be too difficult for some learners.

Authentic material

TV and feature films are just one category in a wide range of video material that can be used in the language classroom. However, unlike some other types of language teaching video material, TV and feature films are not devised for the language classroom, and so they can be used to provide samples of authentic language use. (Note, however, that it is a certain type of language use: films are made from a written script, or screenplay, and therefore much of the conversation which takes place is not *exactly* like the informal, unscripted spontaneous language of everyday use, though there are, of course, many features in common.)



At the same time, because the language is authentic, the use of films will share many of the problems of other types of authentic material, arising mainly from language *difficulty*. Nonetheless, as we will see, there are many ways in which video films can be exploited in the classroom, even at lower levels of language.

Active viewing

A word of warning: Many people spend a large part of their leisure time watching TV programmes or films or going to the cinema. They associate this medium with relaxation and pleasure, and therefore the way in which people watch may tend to be passive and uncritical. However, the use of video in the language classroom requires that learners watch in a rather different way. It can be strange, if learners are not used to it, to find that they are required to watch *actively* and respond to an entertainment medium in a pedagogic situation. This may be particularly true of feature films.

Video films and Graded Readers

Pairing a Graded Reader with its English language film version can create a powerful resource for teaching and learning English.

Sources of language

As well as telling a story through two different media, the book and the film provide different sources of language data. A film will exemplify unsimplified, spoken language while the book presents the narrative through simplified, written language. Thus, and unusually for the classroom, the teacher has examples of two distinct genres of language use which deal with the same topic.

Comprehension processes

Working on a story through two media can help in important ways with both reading and listening comprehension. Firstly, the visual content of films replaces much of the language of the written version, so that the visual information can aid students' understanding of the written text. For example, the film will help the language learner to build a mental representation of the world of the book. Seeing characters on film will help students to distinguish them in the book. Moreover, inference, an important aspect of the comprehension process, depends on an understanding of how the world works, so seeing a film version will provide a student with the requisite information to enable this to take place successfully. The film provides a context within which students can make informed guesses of the meanings of unknown words or phrases in a written text. Seeing pictures first will help students to understand new written vocabulary. In sum, watching a film sequence which matches a section of the book will act as a kind of reformulation of the narrative which will enrich and inform students' comprehension of the written language.

As far as listening comprehension is concerned, the fact that students can read a simplified written version of the narrative will mean that they will find it much

easier to achieve a reasonable understanding of the authentic language of the film. It is also common to find that pieces of conversation in the book actually occur in the film dialogue, sometimes word-for-word and sometimes in a slightly modified form. Thus it will be possible to expose students to samples of real speech in a way that will be relatively enjoyable.

Motivation

As Stephen Krashen has noted, 'Free voluntary reading... is the missing ingredient in intermediate second and foreign language instruction'¹. However, fostering the reading habit, especially in a foreign language, is not an easy task. Using a film version of a book will help encourage students to read for pleasure in the foreign language. If they have enjoyed a film, they will feel positive towards the book, and if they have read the book first they will enjoy seeing the film version.

Classroom activities

Finally, and possibly most importantly, many exciting classroom activities can be devised which make use of the two media. The film and book versions will usually contain interesting differences and similarities which can be exploited in class so that practice in listening and reading skills can be integrated in a natural, authentic way through exercises based on the relationship between the two forms of the story.

Teaching reading and the use of video films

Working with video films is a good way to maintain students' interest and help with their understanding of a story, but how does the use of video films fit in with reading classes and the development of students' ability to read in English?

This guide assumes three broad stages in the reading lesson, namely 'before reading', 'reading' and 'after reading'. The first stage, 'before reading', is used to build motivation, specify reading purposes, establish what is already known about the topic ('activate schemata'), make predictions or pre-teach key vocabulary. During the second stage, the text is read and various reading skills are practised and developed. After having read the text, or a part of it, learners may then work to develop their understanding, and their experience of the text is extended through activities such as discussion, interpretation, or reformulation of the ideas in a different form.

In the reading lesson, teachers may wish, for example:

- to help learners to develop the ability to recognize words and process text rapidly;
- to develop learners' abilities to use different styles of reading depending on their purposes;
- to enable learners to comprehend as fully as possible and to be aware of their responses and interpretations;
- to help them make use of worthwhile strategies while they are 'learner readers', such as guessing meanings from context;

¹The Power of Reading 1993:1 Englewood NJ: Libraries Unlimited Inc.



- to help learners extend their knowledge of structure and vocabulary.

If you are using a Graded Reader as a class Reader, short sections of video films can be used in reading lessons at the *before-reading* and *after-reading* stages, and this is where this guide concentrates most of its attention.

Of course, video films can also be watched after all the reading is done – or even before reading the book - when students may enjoy seeing the whole film in one sitting. Suggestions for exploitation of this approach are also given towards the end of this guide.

Finally, your school may have a library or study centre. Some study centres provide books and tapes for students to borrow, and some also have facilities for students to listen to or watch something on their own. In either case, it is a good idea to have a video library of films which go with the selection of Graded Readers so that students may read individually and then borrow the film of their book. They may find some of the worksheets in this book useful to use at the same time.

Technical points when using video films in class

Equipment

If you have not used video before, here are some important suggestions:

- Familiarize yourself with the equipment. Make sure that you know how to operate the controls for both the television and the video cassette recorder (VCR). Practise if necessary.
- Before the class:
 - 1 Give yourself plenty of time to set up the equipment. Check that everything that needs to be switched on is switched on and that the VCR is working properly (there is nothing worse than saying 'Now we're going to watch a film', pressing the switch – and nothing happens!).
 - 2 Put in the cassette and play a little bit of the film to check that the sound is clear and that there is a good picture. If either of these is poor, students will not enjoy the experience.
 - 3 Adjust the volume control if necessary. Go to the back of the room and check that the soundtrack is clearly audible.
 - 4 Make sure that everyone in the room will be able to see the screen. Make sure that there is no light reflecting on the screen making the picture invisible. Note whether you will need to turn off lights or draw curtains.
 - 5 Find the right place to begin your film and *set the counter on the VCR to zero* so that you can easily rewind to repeat the showing.
 - 6 Find a good place for yourself to be while the video is playing; you need to be able to watch the film and also to control it if necessary.

Features of the VCR and basic techniques for viewing

You can exploit the features of the VCR for different purposes and to create different kinds of activities. These features and techniques are listed below:

1 'Normal' viewing

Everyone can see and hear simultaneously and the film clip is played through without pausing.

2 Repeated viewing

You should expect to rewind and replay the film, or parts of the film, several times in order for students to understand well.

3 Still picture

Using the *pause* or *freeze frame* button will give a still picture. This can be used to concentrate on vocabulary, to predict what will happen, to check comprehension or as a cue to remind students of what they have seen.

4 Silent viewing

By adjusting the *volume control*, students can watch the film without sound. This is very useful. Students can focus only on the visual information as a way of 'previewing' the written text. They can make predictions, supply their own dialogue, or give a simultaneous description of what they see.

5 High speed viewing – backwards or forwards

Use the *slow rewind* button or the *slow fast forward* button to give students a preview of what they will see, or to remind students of what they have seen as a kind of summary. You can use this type of viewing to predict events and pre-teach vocabulary, or you can exploit it for discussion.

6 Sound only

Turn the screen away from the students, or turn down the *brightness/contrast* on the screen, so that the picture is invisible. Students have to guess what is happening from what they can hear.

7 Split viewing

You can create information gaps by dividing the class and turning the screen so that some students hear only, while others see and hear. Alternatively, if you make an audio tape of the soundtrack as well, some students can hear only while others see only. These information gaps can then be exploited in various ways for language practice.

Choosing and developing video materials for Graded Readers

When working with authentic materials, teachers often find they need to spend a fair amount of time choosing suitable materials and devising activities to go with them. Videos of feature films are no exception.

Choosing a video film for a Graded Reader

Some things to bear in mind when **selecting** video films to go with Graded Readers are:



- The film may be linguistically much harder than the book. It may contain accents to which students are not accustomed, or the speed of speech may make it particularly difficult for students to understand. Visual information will compensate for language difficulty to some extent but it may be helpful to give students a transcript at the end of the lesson.
- Unlike the book, the film may contain surprisingly culturally sensitive material, such as bad language, sexual, violent or other material which you or your students may find offensive or difficult for a classroom situation. Don't show the film without watching it first!
- Film versions vary considerably in how similar they are to the book. The film may differ from the simplified Graded Reader in plot, setting, characterization, events, ending, relationships etc. But don't be put off by this: there will usually be many ways in which the film can be exploited.
- It may be useful, especially for lower level students, to use a version of the film which has subtitles in the students' own language. These can be usefully exploited in class, in any case, or if you don't want the students to see them, mask them with some paper.
- If you are only able to find a version of the film in which the dialogue has been dubbed into the student's language, you can still make use of the film by using it purely as a visual aid; in other words, without sound. In the sections which follow, there are many suggestions for silent viewing activities.

Developing teaching and learning materials

Some things to bear in mind when **developing classroom ideas** based on video films with Graded Readers are:

- Choose very short sections or 'clips' (maximum 10 minutes) for class work. It is difficult to maintain interest or to exploit longer extracts for teaching purposes.
- Be sure to leave plenty of preparation time in order to select appropriate clips which match the purposes of the lesson, and to plan accompanying activities.
- A good choice of clip is a scene in the book which is also portrayed in the film. In addition, it is worth looking to see if there are other key aspects such as character, problems to be solved in the story, setting, endings and so on which can be usefully explored through the film.
- If students are at a low level, choose parts of the film which do not have much dialogue.
- Consider using the picture only (silent viewing) to elicit key features of plot, character, event or setting from the students. This is especially useful at the *before reading* stage
- Students should not be expected, even at quite an advanced level, to understand every word of the film dialogue. They may need to be told this.

- Instead, students can be asked to listen for the gist or main ideas of the dialogue and to interpret the visual information on the film; or to listen for specific details of information or key words. (See for example Worksheet 4, sections 3 and 4)
- When you are preparing exercises, it is sometimes helpful to make a transcript of the dialogue of the section you wish to use.

Using video clips with a class Reader: some activities and suggestions

In the sections which follow, ideas for using video clips with a class Reader are organized for convenience into three sections:

- (i) before reading the book or sections of the book
- (ii) after reading short sections of the book
- (iii) after reading the whole book.

Note, however, that this division is not absolute: as in other types of language activity, certain exercises in one section could equally well be used at a different stage in the reading lesson.

Worksheets containing examples of some of the activities described can be found at the back of this guide. A few of these worksheets are designed for certain films and/or books. However, where the worksheets are very specific, the intention is to provide a model so that teachers can devise similar worksheets for other films or books.

(I) BEFORE READING THE BOOK OR SECTIONS OF THE BOOK

This section contains ideas for activities to be done before students read the text, either the whole book or each part of the book.

Showing scenes from the film will help students to prepare for understanding the written text by:

- providing background information on character and setting (time and place) and allowing students to form mental pictures;
- building expectations of events and plot;
- enabling the pre-teaching of key vocabulary in the written text.

At the same time, the students will have practice in listening comprehension.

Using video to preview the story

Use these activities to help students to prepare for comprehension of the written text. The activities will activate students' background knowledge, establish a few key concepts in the story and encourage predictions.

- Play a few short sequences from the beginning, middle and towards the end of the film. Discuss what type of story it is, and what events students might expect. Ask them to suggest some chapter headings for the book.



- Play a clip, or short scenes from a clip, that corresponds to a chapter of the book. Ask students to suggest the chapter title.
- Play the part of the film which gives the names of the film stars (usually the beginning). If the actors are known to the students, they can list the actors and say what roles they might have. There may be a list of characters at the beginning of the book which you can use for this.
- Play a short sequence once or twice on slow fast forward or on slow rewind. In pairs, students try to reconstruct the events on the film. They then read the text.
- Make use of the book cover and the video cover or film poster. Students look at the title, chapter headings, pictures, story outline on the back of the book, and video cover or film poster. They discuss in groups what might happen in the story and what might be the opening scene of the film. Then play the opening scene; students can see if they were right.
- Use the cast list at the end of the film to show the names of the main characters. Then ask students to scan the book or chapter to see if the same characters appear.
- Use the early parts of the film to establish the main characters and help students get a clear mental picture of who is who before they start the book. Here is an example worksheet (**Student's Worksheet 1: Establishing the characters**) of how this can be done, using the book *Madame Doubtfire* by Anne Fine (Penguin Readers, Level 3) and the film 'Mrs Doubtfire' starring Robin Williams & Sally Field. (Made in 1997 by 20th Century Fox. (PG¹):

For teacher's instructions see the following notes. For photocopyable Student's Worksheet, see the end section of the book.

Pre-teach *clip* (a short section of film), *character* (a person in a story), *appearance* (what somebody looks like), and *role* (the part/position somebody plays in a story).

- 1 Play the first few frames of the film, with sound, containing the opening titles etc. During these frames, we see the father (played by the actor Robin Williams) at work putting a soundtrack onto a cartoon film.
- 2 Pause the film after a few seconds at a point where there is a good shot of the father. Students complete the box for character 1.
- 3 Ask students to say what role they think this man will have in relation to the other characters.
- 4 Then fast forward to the shot of this man with some children. Play a little of this scene without sound. Ask students to say what is happening.
- 5 Pause where there is a shot of the man together with the children. Students fill in the point of the star with his role (ie father of the family).
- 6 Students complete the details for characters 2, 3 and 4 in the boxes and their roles (the daughters and son).
- 7 Finally fast forward again to the shot of a woman in an office. Play this part with or without sound.
- 8 Students complete the details for character 5 in the box. Also say what they think her role in the film is (ie wife/mother).
- 9 Ask the students to say from whose point of view they think the story will be told (ie, the 'most important character')

- 10 Now refer to the back of the book. Ask students to read the back cover: can they fill in any names? Put the name of the family in the middle of the star.
- 11 Check that everyone now has a picture of the family. The children's names can be given to the students, or you can wait until they look at the first chapter of the book, after which they could add the names to the star.
- 12 Alternatively, you could ask students to look at the book at home and to complete the diagram with the names of the family and its members.

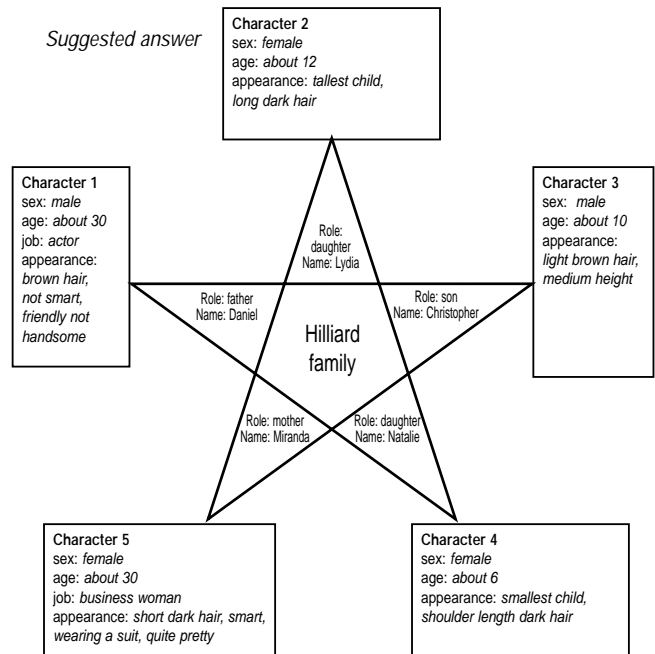

'Most important character' = father. The story is told from his point of view. He is shown first.

- If you are introducing a new chapter in the book, start the video viewing session with a still picture to help recall the story, or play a short sequence and then pause the film. Ask the students to say what is happening in the picture, and what has just happened. Ask them to say, or act out, what they think will happen next. What X is going to say next? What is X going to do next?
- Some recent readers have still pictures from the film printed in them (for example, the following Penguin Readers: *Emma*, *The Borrowers*, *Four Weddings and a Funeral*). You can combine these pictures with a clip from the film to preview the chapter or section which students are about to read. Here is an example of how to do this using *Emma*, by Jane Austen (Penguin Readers, Level 4, Pages 40-43) and the film 'Emma' starring Gwyneth Paltrow (made in 1996 by Miramax International (U)). Use **Student's Worksheet 2: Previewing a part of the book**.

For teacher's instructions, see the following notes. For photocopyable Student's Worksheet, see the end section of the book.

First find the section of the film which deals with the picnic at Box Hill. The clip begins with a shot of a country landscape and a group of people seated on the grass, and ends with the scene in which Mr Knightley reprimands Emma for her unkind words to Miss Bates.

Then:

- 1 Ask students to read through the questions in exercise 1 on their worksheet. Play the film clip right through once **without sound**,



¹The British Board of Film Censors gives all films an age rating as follows:

U = universal – suitable for all ages U_c = suitable for all, especially children PG = suitable for children with parental guidance 12 = suitable for people aged 12 and over 15 = suitable for people aged 15 and over 18 = suitable for people aged 18 and over

pausing it from time to time so that students can answer the questions. Ask them to tell you when they can see the characters listed.

- 2 Then ask the students to look at the picture in their book on page 41 and say who they think has just spoken (exercise 2 on worksheet).
- 3 Ask students to read through exercise 3 on their worksheet. Replay the film clip from the beginning, this time **with sound** and stop it when you reach the still picture in the book. Students can say whether their answer to the question in 2 was correct. Repeat the relevant part of the film so that students can complete Frank's words on their worksheet ('Shall we **play a game?**')
- 4 Ask students to read through exercise 4 on their worksheet. Play the remaining part of the clip through again without sound. Students make notes on the questions. You could ask different students to make notes on different questions. Students can then discuss answers in pairs or groups.
- 5 Finally, for homework or in class, ask students to read pages 40-43 in the book.

Using video for vocabulary teaching

Use these activities for vocabulary development and to help pre-teach vocabulary which occurs in the written text. This kind of exercise is very useful where the story contains culturally specific elements. An example of this is the sheepdog trials scene in 'Babe' (made in 1995 by Universal City Studios (U); book *Babe - The Sheep Pig* in Penguin Readers series, Level 2). You can show a still picture from the scene, or a short sequence such as where the pig enters the ring at the start of his competition, in order to help students understand what he has to do and what kind of place it is.

Setting and visual details

- Use a video film to enable students to get a clear picture in their minds of the story setting before they read, and also to learn any key vocabulary they will need for the story. See **Student's Worksheet 3: Getting the picture**. A suggested procedure is as follows:

For teacher's instructions see the following notes. For photocopiable Student's Worksheet, see the end section of the book.

- 1 Put students in pairs and arrange them so that only one of the pair (student A) can see the screen.
 - 2 Play a clip **without sound**, or a **still picture** while student B asks questions to try to guess what his or her partner is looking at.
 - 3 Student B tries to guess what type of scene his/her partner was looking at. Then get them both to look at the screen and to talk about what they can see.
 - 4 You could ask them to look in their dictionaries for new words that they might need, and to check pronunciation.
 - 5 For homework, students could be asked to write a short description of the picture they have seen, using any new words they have learnt.
- Choose a part of the film which shows an object or a place, and pause the film. Stick several pieces of paper over most of the screen (use damp paper, or blutac or sticky tape). Ask students to say what they think is in the still picture. Gradually reveal the picture. Build a list of the vocabulary students need to describe the picture.
 - One student comes to the front to look at the screen. Turn the screen away from the rest of the class and pause the film, or play a short sequence without sound. The class asks the student questions to

establish what is in the picture (see **Worksheet 4, section 1** for an example).

- Split the screen: use a large piece of card or a movable blackboard to put at a right angle in front of the screen so that half the class sees one half of the screen and the rest of the class sees the other half of the screen. By asking each other questions, students try to establish what is on the part of the screen they can't see.

Character

- Make a list of words or phrases from the book describing character traits, physical features or other important facts. Show short clips or stills of the main characters and ask students to match the sets of words with each visual image of the character.
- Choose a sequence with five or six different characters appearing consecutively. Turn the screen away from the class and turn the sound off. Individual students take turns to watch a small part of the sequence. As each student watches, he/she describes each character on screen to the class. The class try to decide who the characters are and how many there are.
- Show a clip in which a series of events occur (maximum 10 minutes). While they watch, students list the characters involved. Then they work in groups to think of words which describe the characters. Ask students to justify their choice of words by recalling incidents from the clip. Use **Student's Worksheet 5: Thinking about character**, for this activity. Note that this worksheet can be done before reading a new part of the book, or equally well after students have read a section or chapter.

Comprehension of the video clip

When you use a video clip as part of your pre-reading stage, you will obviously want to make sure that students have understood what they have seen. The following activities:

- help to check comprehension of events, plot and dialogue in the film clip;
- provide the opportunity for language practice;
- prepare students for reading by familiarizing them with the story.

Note, however, that many of the following activities could also be done after students have read the text. Using the activities in this way will give students the opportunity to recycle language from the book.

Events and plot

In these activities, students can work in pairs or small groups. This will give them plenty of opportunities for language practice.

- Exploit an early sequence from the film which identifies one of the main problems to be resolved or which sets the scene for the story before students start to read. Here is an example of how to do this using the film 'Mrs Doubtfire' and the book *Madame Doubtfire* (Penguin Readers, Level 3). Use **Student's Worksheet 4: The starting point**.



For teacher's instructions, see the following notes. For photocopyable Student's Worksheet, see the end section of the book.

A suggested procedure is as follows:

Pre-teach the following words: *clip* (a short piece of film), *character* (a person in a story), *expression* (the look on somebody's face), *divorce* (the end of a marriage)

- 1 Ask students to read exercise 1 on their worksheet. Play the clip **without sound**. Students complete the questions on the worksheet while or after watching.
An alternative to this would be to turn the screen away from the class and ask one student to come and watch the film. The class ask the student the questions on the worksheet.
- 2 Ask students to read exercise 2 on their worksheet. Play the clip again, this time with sound, pausing to elicit answers to the questions. Even if students cannot understand the language well, they will be able to tell how the characters are feeling.
- 3 Play the clip once more for the students to complete the tapescript in exercise 3 on their worksheet.
- 4 Finally, tell the students that this scene happens before the book starts. Ask them to suggest how the story might continue, or what kinds of thing might happen.
- 5 For homework, you could ask the students to imagine that they are one of the characters, perhaps one of the children, and to write about the scene as an entry in a diary, describing what happened, how they felt and what they think could happen.

Tapescript

The clip begins where Miranda is tidying up after she has arrived home to find Daniel and the children having a birthday party.

- Miranda: Why am I the only one who feels there have to be rules? Why do you always make me out to be the heavy?
- Daniel: I don't make you out to be anything. You do it yourself quite naturally, Miranda.
- Miranda: You set me up, Daniel, every time.
- Daniel: I don't set you up. Oh lighten up, will you? Just realize you're spending too much time with those corporate clones you used to despise.
- Miranda: I spend too much time with you, Daniel. It's over. It's over.
- Daniel: Come on, Miranda. Listen. We've got problems, but who doesn't? We can work them out. What are you talking about, it's over?
- Miranda: We've been trying to work them out for fourteen years.
- Daniel: Come on, please. Listen. Maybe we need some help, OK? Maybe we can go to a family therapist. They'll help us through this together.
- Miranda: It's too late for that.
- Daniel: Well, let's take a vacation together with the kids, as a family. Get you away from work, you're a different person, you really are. You're great.
- Miranda: Oh Daniel. Our problems would be waiting for us right here when we got back.
- Daniel: Well, we'll move. We'll hope our problems won't follow us.
- Miranda: Daniel, please don't joke.
- Daniel: OK.
- Miranda: We've just grown apart. We're different. We have nothing in common.
- Daniel: Oh sure we do. We love each other. Come on, Miranda. We love each other. Don't we?
- Miranda: I want a divorce.

(cut to shot of children watching them)

- Students watch a film clip and then work together to draw, or complete, a flow chart or diagram which summarizes the events. Replay the clip: are the diagrams correct? (See **Student's Worksheet 8: Timelines: same or different?** for an example of a suitable diagram.)
- Students watch a film clip and then together decide what vocabulary they will need to retell the story. Play the clip in short sections, pausing to allow students to discuss and make notes. Replay the clip

silently while individual students take it in turns to give a commentary on what is happening.

- Play the clip with sound only. Turn the screen away from the students, or turn down the *brightness/contrast* on the TV. Then, in pairs or groups, students say or write what they think happened. Replay the clip, this time with the picture: were they right?
- Ask some students (group A) to listen carefully for information on one topic while other students (group B) listen for another topic. Each student writes notes on what they hear. In their groups, they confirm what they have heard. Then pair the students so that A students work with B students. The students watch the clip again while referring to their partner's notes. Are the notes correct? (**Worksheet 2, section 4** shows a set of questions which are suitable for this type of activity.)
- Some students see the picture only, while others hear the sound track only (use an audio tape in another room). Then, in pairs from each group, they try to reconstruct the events.
- One half of the class sees the sound *and* picture (group A), the other half only hears the sound (group B). (Turn the screen away from one half of the class, or ask half the class to sit with their backs to the screen.) Then in pairs, B students try to establish what happened by asking A students questions.
- If the film has subtitles in the students' language, choose a short section (two or three minutes), mask the screen so that only the subtitles are visible and play the clip without sound. Afterwards, ask students to say: how many people they think are in the scene and what sort of people they might be. In pairs, get the students to compare their ideas on what they think happened in the clip. Play the clip again with full vision and sound: were they right?

Detailed listening to dialogue

Working with dialogue involves comprehension of authentic speech. This may be quite difficult, so prepare a tapescript to give to students, preferably after they have listened two or three times.

- Ask students exactly what was said in a very short sequence (one or two sentences). This could be done using a short piece of tapescript with gaps which students fill in. Alternatively allow the students to control the VCR themselves, pausing and rewinding until they can repeat exactly what was said. (For examples see **Student's Worksheet 2, section 3** or **Student's Worksheet 4, section 3**)
- If the film has subtitles in the students' own language, play a clip without sound. Ask students to prepare the dialogue in English. Compare their version with the film, using a tapescript if necessary.
- Alternatively, play the film clip with sound and picture but mask the subtitles. Pause the film from time to time and ask the students to write down or suggest their own 'subtitle' for the sentence of



English dialogue they have just heard. Unmask the subtitle so they can compare their answers with the original.

- From a film clip, list some important quotations. It is useful if these quotations are also in the written text. Before they watch the clip, ask students to say who they think said the words. Then play the clip and ask students to tell you when they hear the words.

(II) AFTER READING SHORT SECTIONS OF THE BOOK

This section contains ideas for activities to be done after students have read short sections or chapters of the book, and require that the relevant part of the film is not seen first.

These activities are designed to extend students' comprehension through close examination of the written text and through exploitation of the differences between the film and book versions. In addition to practising aspects of listening comprehension (for example, gist-level understanding of the dialogue, listening for specific words), students will also be engaged in 'video comprehension', that is, understanding the story as it is shown through words and pictures. The activities will encourage greater critical awareness of techniques of film-making and story-telling, enabling students to see how a film may play with narrative by making changes, and condensing or expanding text.

Inferring

This level of comprehension requires students to go beyond the text itself and to 'read between the lines'. Comprehension of the written text needs to be very good in order to understand implications and to use these to imagine a visual form of the text.

- Select phrases or sentences in the book which are portrayed more or less exactly in the film. Reproduce the phrases or sentences on a sheet of paper for the students. Ask the students to imagine how these sentences will be portrayed in the film. Then look at the film to see how the sentences are realized. Examples of suitable aspects are: facts, places, physical characteristics, actions, events, relationships, moods or emotions etc.

An example of how to do this is shown in **Student's Worksheet 6: From book to film**, which is based on the book *Forrest Gump* by Winston Groom (Penguin Readers, Level 3, pages 14-16), and the film 'Forrest Gump' starring Tom Hanks (made in 1994 by Paramount Pictures (12)). First find the clip which begins 'One day it started to rain and didn't quit for four months' and ends with 'Bubba was going to be a shrimping boat captain but instead he died right by that river in Vietnam'. The clip lasts approximately 10 minutes.

For teacher's instructions, see the following notes. For photocopiable Student's Worksheet, see the end section of the book.

- 1 Ask students to do exercise 1 on their worksheet (they read their books from 'The weeks went past slowly' on page 14 to the end of page 16). They could read it at home before the class.
- 2 Ask students to do exercise 2 on their worksheet. Ask them to work in pairs and then report back to the class.
- 3 (Worksheet, exercise 3) Play the clip **with sound**. Ask students to tell you to stop the film when they think each sentence is being shown on the film (or stop it yourself). Discuss whether the scene is as students imagined. At the same time students should number the events in the order in which they happen in the film.

Answer

(i) I also wrote a letter to Jenny Curran.	3
(ii) Bubba and I decided that we would get a shrimp boat when we got home.	2
(iii) It started to rain and didn't stop...	1
(iv) But we still had to look for enemy soldiers and one day we found them.	4
(v) I looked round for Bubba but he wasn't there...	5
(vi) I saw another man who was hurt... so I picked him up...	6
(vii) Then I ran... and found Bubba.	7
(viii) He said something very softly... and then he died.	9
(ix) An American plane came and used fire throwers.	8

- 4 (Worksheet, exercise 4) Play the clip once. Students write S or D next to each sentence from the book according to whether it is the same in the film or different. Note that the realization of sentences in the film may be through a piece of dialogue or a visual detail or through a fact or event in the story: Answers are:

- (i) Bubba planned it all. (S)
- (ii) It started to rain and didn't stop for two months. (D – 4 months in the film)
- (iii) We were crossing a rice field when suddenly they started shooting at us. (D – in the film they are in a forest)
- (iv) There was blood all over him and he had two bullets in his stomach. (S – as far as we can tell)
- (v) He looked up at me and said, 'Forrest, why did this happen?' (S)
- (vi) Somebody shot me in the back of the leg. (D – in the film Gump was shot in the buttocks. NB his pronunciation of this word is a little strange!)

- 5 Students read pages 14-16 of their books again. They can discuss question 5 on their worksheet in pairs first and then have a class discussion. Alternatively, for homework, students could identify, or mark on a photocopy, the places in the text which have been left out of the film.

- Choose one or two pages from the book. Play the corresponding part of the film. Ask some students to identify the parts of the text which are portrayed exactly in the clip. Ask other students to concentrate on the parts of the text which are shown but have some differences in the film. In pairs, students compare their findings.



- Choose a part of the book in which something, for example, an aspect of character or a relationship, is not directly stated. Devise prompts or questions which ask students to say what they think is implied. Show the corresponding part of the film. Does it confirm what they thought? An example of how this might work is with the character of Emily in *The Mosquito Coast* (Penguin Readers, Level 4). There is a scene in the book in which she talks to the boy Charlie while on a boat. The book does not say much about her character, but it is possible to infer something about her motives for talking to Charlie. Students can be asked to imagine what type of girl she is, even her style of dress, and then after seeing the clip, to say whether she was as they imagined.

Same or different?

- Choose a section of the book which is easily matched with a film clip. Pick out some sentences which contain factual information. Ask students to watch the video clip of this section and to say whether each sentence is the same or different in the film. An example of how this can be done is shown in **Student's Worksheet 6, section 4** as above.
- Alternatively select some sentences of dialogue which occur more or less the same in the film and ask students to listen and say whether the sentences are exactly the same or different in the film. This exercise will give practice in detailed listening to authentic speech. However, because the students have already read the words in the book they will find it relatively easy to identify the spoken words and also to guess the meanings of different words used in the film. An example of this activity is on **Student's Worksheet 7: Conversation: same or different?** Follow this procedure:

For teacher's instructions, see the following notes. For photocopiable Student's Worksheet, see the end section of the book.

- 1 Select five sentences spoken by characters in your book which are more or less the same in the film. Dictate them to students; students write them on their worksheet.
 - 2 Put the students in pairs to discuss who is the speaker of each sentence and where, when and/or why the sentence was spoken. Students write their answers on their worksheet. Check the answers with the whole class.
 - 3 Now play the film clip and ask students to listen carefully for their sentences. When they hear the sentences, students should tick the 'same' box if the words are identical, or the 'different' box if there are some different words in the sentence. Or you could ask the students to tell you to stop when they think they hear the sentences.
 - 4 Play the clip once more so that students can write down exactly what was said if the spoken words are different. E.g. In book 'How could you be so cruel to Miss Bates?' In film: 'How could you be so *unfeeling* to Miss Bates?'
- You could also ask each student to select from the text a sentence spoken by a character. Then watch the clip. Whenever students hear their quotation, or something like it, they should ask you to pause the film. Ask students: is the quotation exactly the same in the film? If not, how is it different? Are all the quotations chosen by the students included in the film?

- If the film has subtitles, from a clip select some subtitles which match pieces of dialogue in the book. Play the clip without sound and pause it when your selected subtitle appears. Can students find the matching piece of dialogue in the book? Repeat the scene so that the film dialogue can be heard: are the words in the film the same or different from the book?
- Make a list of key episodes from a chapter or a short section – one to three pages - in the book. Or ask students to do this. Then students watch the corresponding part of the film and number the episodes in the order in which they occur in the film. Ask them to suggest possible reasons for any differences. As we have seen already, **Student's Worksheet 6, sections 2 and 3** show one way to do this. In addition, **Student's Worksheet 8: Timelines: same or different?** provides an example of this activity. Follow this procedure:

For teacher's instructions, see the following notes. For photocopiable Student's Worksheet, see the end section of the book.

- 1 Select a suitable section from the book (one to three pages). For homework, students identify the most important events and write them in the boxes on the 'book timeline'.
- 2 In class, students can compare their answers. You may need to provide a 'correct' version for them.
- 3 Then play the corresponding part of the film. You could play it on *slow fast forward* first and then ask students what events they saw.
- 4 Play the clip at least once through on normal viewing.
- 5 Repeat the clip one or more times, pausing as necessary, so that students can complete a timeline for the film.
- 6 Again, provide a 'correct' version for the students. Or, if you have access to an overhead projector, make a copy of the film timeline on a transparency, and complete the film timeline yourself in class from suggestions elicited from the students.
- 7 When both timelines are complete, students should draw lines from the boxes on the book timeline to matching boxes on the film timeline so that it can easily be seen how the book and film differ.
- 8 Finally, discuss the remaining questions on the worksheet with the class.
- 9 For homework, students can write a short summary of the scene in the book or the scene in the film, using the timelines to help them.

Further suggestions for homework

This section contains suggestions for homework in addition to those under the teacher's notes for the worksheets.

- Choose a page from the book. Ask students to try to visualize the contents and to draw a picture or series of pictures to show what happens. Then in class, they watch the corresponding part of the film. Students then discuss differences between their pictures and the film.
- Choose a part of the book with some reported speech. Ask students to convert it to dialogue. Students can compare their versions with the film either through looking at the tapescript and/or watching the corresponding clip.
- Make a tapescript of a short scene (or use an



original screenplay if you can find one). Discuss with students how formal or informal the scene is. Ask them to find examples in the tapescript of language that is either very formal or very informal.

- Choose an episode from the chapter students are reading, show the corresponding clip, and then ask students to write a short screenplay or story from a different character's point of view.

(III) AFTER READING THE BOOK

The activities in this section can be used when students have read a large part or all of the book and are quite familiar with the story.

These activities are intended to extend students' experience of the book beyond comprehension of the text by encouraging individual responses and a critical approach to the story. The activities also provide the opportunity for natural integration of the four language skills (reading, writing, speaking, listening).

Using clips

Use video clips as reminders or as prompts for students' own responses.

Analysis of character

- Show short clips or stills of the main characters. Ask students to discuss what was the most important thing each did in the story. Which characters do the students like and which don't they like? What are the characters' strengths and weaknesses? Would the students have behaved in the same way in the same situation? An example of this activity is shown on **Student's Worksheet 9: Remembering the characters**. Follow this procedure:

For teacher's instructions, see the following notes. For photocopyable Student's Worksheet, see the end section of the book.

- 1 Select some scenes from the early parts of the film and show these to the students.
- 2 Tell the students to work in small groups and to choose one or two of the characters they have just seen. They should discuss the questions on the worksheet and try to agree on a group answer. When they have decided on their answers they should write them on the worksheet, in note form.
- 3 Each group should elect one person to present the group's answers to the rest of the class.
- 4 Alternatively, for homework students can use their notes to write a short essay on the two characters.

Retelling the story

- As prompts, use stills from the beginning, middle and end of the film. Ask students to retell the story in written or spoken form.
- Play a short sequence on *slow fast forward*, or *slow rewind*. Which scene is it? Can students remember when it happened in the story? Ask students to retell the scene in written or spoken form.
- Play a short sequence without sound, pausing to ask students if they can remember any of the dialogue.

Endings

- Discuss the ending in the book with students. Is it satisfactory? Can they imagine a different ending? Show the ending in the film. Is it the same as the book? If different, is one better than the other?

Using the whole film

You may decide that, having seen a few extracts, the students should see the whole film in one sitting. This will enable you to do various other activities involving discussion and opinion. For example:

- Students choose their favourite part of the film. Does this part also happen in the book? If so, show the film clip and locate the part in the book. Compare any differences between the book and the film. An example of this activity is shown on **Student's Worksheet 10: Favourite scenes**. Follow this procedure:

For teacher's instructions, see the following notes. For the photocopyable Student's Worksheet, see the end section of the book.

- 1 Arrange the students in groups of three or four. Each person in the group should think of one or two scenes that they liked from the film and tell the rest of the group. On their worksheet, the students should list all the scenes mentioned.
- 2 Having done this, the group should then try to agree on the most popular scene, and to number the remaining scenes in order of the group's preference. They may need to decide this by voting.
- 3 One person from each group should then tell the class which was their group's favourite scene. Write each one of these on the board, and then try to determine the whole class's favourite scenes by a having a vote.
- 4 Before the next class, choose a clip of one of the class's favourite scenes **which also happens in the book**.
- 5 In the class, play the clip to the students and tell them to make notes on the setting (where the scene takes place), characters (who is in the scene), and what happens. They could also write down short pieces of key dialogue if they are able to.
- 6 Then tell the students to find the scene in the book, and to make notes on the setting, the characters and what happens. They could also look to see whether pieces of dialogue they have written occur in the book.
- 7 In pairs, they compare their answers and discuss which they preferred, the book or film version.
- 8 If you wish, for homework students could use their notes to write a short comparison of the scene in the book and as it is shown in the film.

- Students can compare the book and the film: what's missing/added/different/the same? Which did they prefer? An example of this activity is shown on **Student's Worksheet 11: Book compared to film**. Follow this procedure:

For teacher's instructions, see the following notes. For photocopyable Student's Worksheet, see the end section of the book.

- 1 Tell students to work in pairs or in small groups and together to try to complete the worksheet in note form.
- 2 They should also discuss whether they preferred the book or film version and why.
- 3 Finally, they can present to the rest of the class the main differences and similarities they have noted, and also give their opinions on the book and film versions.
- 4 Alternatively, for homework they can write an essay giving their opinion on which is better: the film or the book.



- Ask students to criticize aspects of the film. For example, does it show violent scenes? Do students think these are necessary? How does the book deal with violence?
- Ask students to discuss moral aspects of the story. For example, in 'Mrs Doubtfire' the children are unhappy because of their parents' divorce. Should couples be able to divorce when they have children?
- From whose *point of view* is the story told in the book? Does the film use the same point of view? Discuss similarities and differences.

Projects

Using short sections or clips

- Photocopy one or two pages from the book. Ask students to imagine they are going to make a film of this part. Ask students to mark the text (cutting out or highlighting different parts) to show the different scenes, characters and dialogue they would include. They should number the scenes and discuss whether each one should be filmed in a studio or on location. They could even make a storyboard. When they have finished, they can watch the corresponding film clip: how similar is it to their ideas?
- Students can make their own tapescript of a short scene in the film. Ask them to mark the places where there is a cut and add details of the actors' actions.
- Choose a short scene from the film to work on. Students work in small groups. Watching the clip without sound, each group devises their own dialogue. They will probably need to write this down, and have several rehearsals. When they are ready, they add their own soundtrack to the clip in a live performance to the class.

Using the whole story

- Students make a poster for the film showing the part of the story they liked best.
- Students write a different ending for the story. This could be as a straightforward narrative, or in dialogue form (ie words only), play form (with stage instructions) or screenplay form (with camera instructions).
- Students write a TV guide or magazine review of the film, including its good and bad features, interpretation of the book, opinions of the actors, and a star and age rating. Or the review could be presented orally. An example plan of how to write a review is shown on **Student's Worksheet 12: A film review**. A suggested procedure is:

For teacher's instructions, see the following notes. For photocopyable Student's Worksheet, see the end section of the book.

- 1 Tell the students they are going to write a film review – in English, of course!
- 2 Discuss with the students who the readers might be. Could the review be published in a school magazine or on the Internet? How long will it be? For example, those in TV guides or local newspapers are quite short and are intended to help people decide whether to watch a film. National newspapers or magazines are longer and usually make an artistic assessment. It may be helpful

to provide examples of the type of review you would like students to imitate.

- 3 Explain any concepts on the worksheet which are new to the students. They can then complete the worksheet at home or in class.
- 4 When the worksheet has been completed, students can discuss their answers with someone else. This will help them to clarify their ideas.
- 5 Finally, in class or for homework, they write the review.

Surveys

After reading the book and/or seeing the film, a number of different types of survey are possible. Surveys involve several different skills and are valuable teaching and learning exercises.

Possible topics for a survey are: opinions of the film; opinions of the book; which was preferred, the book or the film; the most popular actor; favourite scenes.

Surveys can be conducted among different groups of people, for example: the class, year group, school, teachers, parents, siblings, other family members etc.

The survey questionnaire should be written first, in English or the mother tongue depending on the intended respondents.

The findings should be written up and/or presented in statistical or graphic form. Or the students could make short oral presentations in class. Are there any clear patterns in the findings? For example, do boys have the same or different opinions from girls? Do opinions vary according to age?

Bibliography

Lavery, M *Active Viewing Plus* (Modern English Publications, 1986)

Cooper, R, Lavery, M & Rinvoluceri, M *Video* (Oxford University Press, 1991)

Stempleski, S & Tomalin, B *Video in Action – recipes for using video in language teaching* (Prentice Hall International, 1990)

Lonergan, J *Video in Language Teaching* (Cambridge University Press, 1984)



Establishing the characters

Watch the video clip and complete as much of the following as you can.

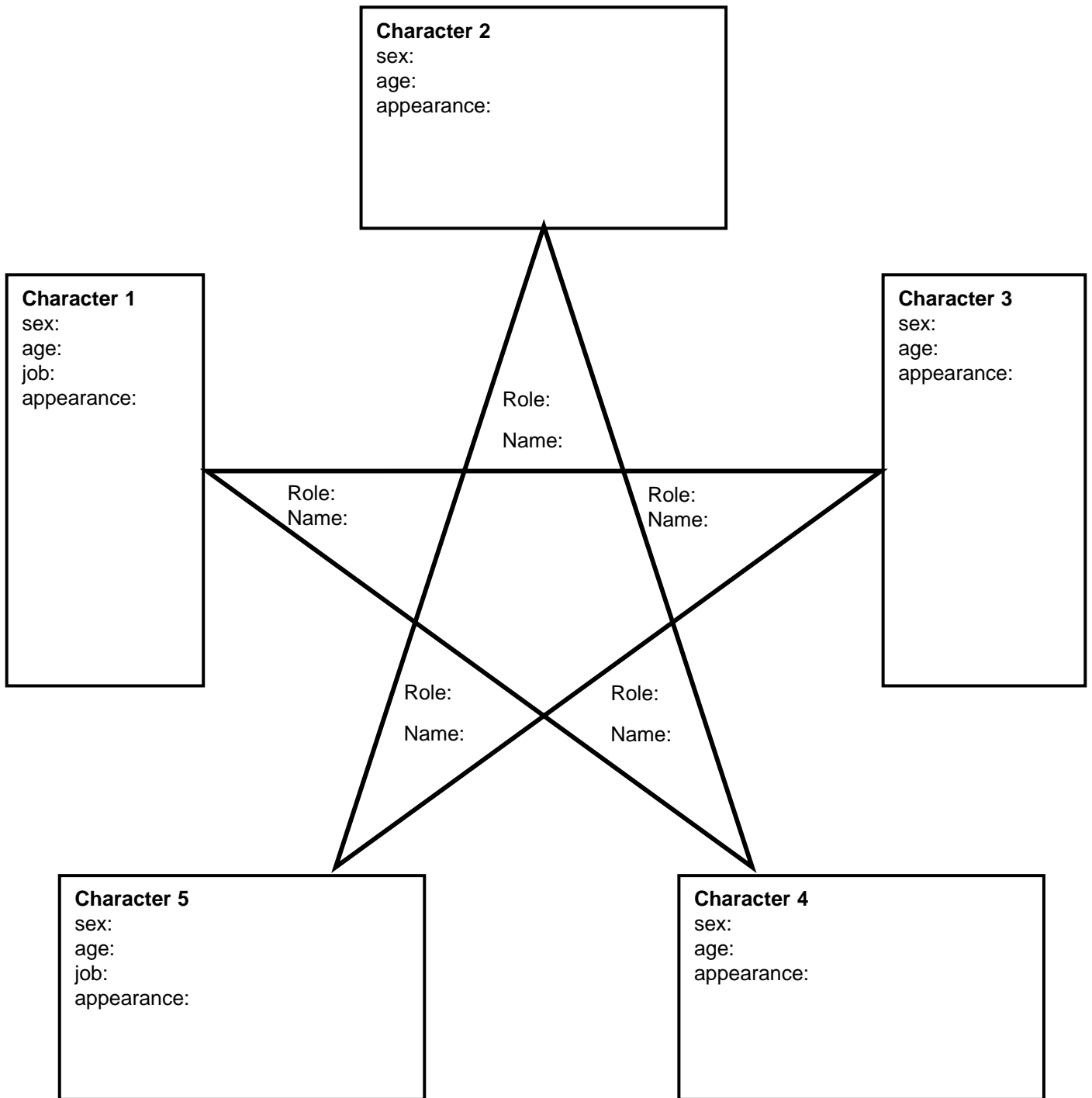

- Who do you think will be the most important character in the story? Why?



Previewing a part of the book

Example: Book: *Emma* – by Jane Austen (Penguin Readers, Level 4, Pages 40-43)

Film: 'Emma' starring Gwyneth Paltrow (PG)

Made in 1996 by Miramax International

1 Your teacher will play a video clip **without sound**. Answer these questions:

- Where are the characters?
- What are they doing?
- Can you see these characters?

Frank Churchill Jane Fairfax Mrs Elton Mr Elton

What are they eating?

- Say when you can see these people:

Harriet Emma Miss Bates Mr Knightley

2 Now look at the picture on page 41 of your book.

- Who do you think has just spoken?

3 Watch the video clip again as far as the picture in the book – **with sound** this time. Was your answer to the question in 2 above correct?

- Complete this sentence with the words used in the film:

'Shall we a

- Who says these words?

4 Now watch the rest of the video clip **without sound**. As you watch, make notes on these questions:

- (i) What do Mr and Mrs Elton do?
- (ii) What does Emma do?
- (iii) What does Miss Bates do?
- (iv) What do Miss Bates and Mr Knightley do together?
- (v) Why do you think Emma is crying?

Discuss your answers in pairs or groups. Then read pages 40-43 in your book.



Getting the picture

Work in pairs.

Student A: Look at the screen. Your partner will ask you questions about what you can see. Don't speak unless you are asked a question.

Student B: Turn away from the screen so that you cannot see it. Have a pencil ready to make notes. You should ask your partner questions so that you can try to find out **what sort of place** he/she is looking at. Here are some examples of questions you can ask:

- 1 Can you see any buildings? If yes:
How many are there?
What are they/is it used for?
Are they/is it big or small?
What colour are they/is it? .
- 2 Can you see any people? If yes:
How many are there?
What are they doing?
Are they male or female?
Are they old or young?
- 3 If you could hear any sounds, what would you hear?
- 4 What could you smell if you were there?
- 5 Can you see any objects? If yes:
What are they?
- 6 Can you see any animals? If yes:
What kinds of animal are there?
What are they doing?
- 7 Can you see any plants or landscapes? If yes:
What sort of plants?
What sort of landscape?
- 8 What about time?
What time of year is it?
What time of day is it?
What historical period is it?

At the end of the questioning session, Student B: say what place you think your partner was looking at.

Now both of you watch the clip or look at the picture. Talk about what you can see. Check that you both know all the words you need. Use your dictionaries.



The starting point

Example: *Book: Madame Doubtfire (Penguin Readers, Level 3)*
Film: 'Mrs Doubtfire' starring Robin Williams & Sally Field
Made in 1997 by 20th Century Fox

- 1 Look at these questions first. Your teacher will play a clip **without sound**. Answer the questions.
 - a) Who can you see in the film?
 - b) Where are they?
 - c) What do you think happened before this?
 - d) What are they doing?
 - e) What do you think they are saying to each other?
 - f) Can you suggest the exact words?
 - g) What do you think the characters' feelings are?
 - h) Who is watching them?

- 2 Now look at these questions and watch the film again, this time **with sound**. Answer the questions:
 - a) Were any of your suggestions for question f) right?
 - b) Listen carefully to the way in which the characters speak to each other. How do their feelings seem to change through the scene?
 - c) Can you think of some words to describe the expressions on the characters' faces?
 - d) What are their opinions of each other?
 - e) What are the children thinking? How do they feel?

- 3 Listen one more time to the film clip and fill in the missing words from this tapescript. One word is missing from each space:

Miranda: Why am I the only one who feels there have to be ? Why do you always make me out to be the heavy?

Daniel: I don't make you out to be anything. You do it yourself quite naturally, Miranda.

Miranda: You set me up, Daniel, every time.

Daniel: I don't set you up. Oh lighten up, will you? Just realize you're spending too much time with those corporate clones you used to despise.

Miranda: I too much time with you, Daniel. It's It's

Daniel: Come on, Miranda. Listen. We've got , but who doesn't? We can work them out. What are you talking about, it's over?

Miranda: We've been trying to work them out for years.

Daniel: Come on, please. Listen. Maybe we need some , OK? Maybe we can go to a family therapist. They'll help us through this together.

Miranda: It's too for that.

Daniel: Well, let's take a vacation together with the kids, as a family. Get you away from work, you're a different person, you really are. You're great.

Miranda: Oh Daniel. Our problems would be for us right here when we got back.

Daniel: Well, we'll move. We'll hope our problems won't follow us.

Miranda: Daniel, please don't

Daniel: OK.

Miranda: We've just grown apart. We're We have nothing in common.

Daniel: Oh sure we do. We each other. Come on, Miranda. We love each other. we?

Miranda: I want a

- 4 What do you think will happen in the story?



Thinking about character

Your teacher will show you a short part of the film accompanying your book.

While you watch, make a list of all the characters you see in the film clip, using the table below:

	character 1	character 2	character 3	character 4	character 5	character 6
name						
role in the story						

- In pairs or small groups, choose two of the characters from your table and think of words which describe the characters' qualities, using a dictionary to help you if necessary.
- What happened in the clip to show you what qualities the characters have? Think of events which support your choices of words.
- Complete the diagram below. In each quarter of the circle write a quality. In each diamond write what happened to show why the character has the quality.

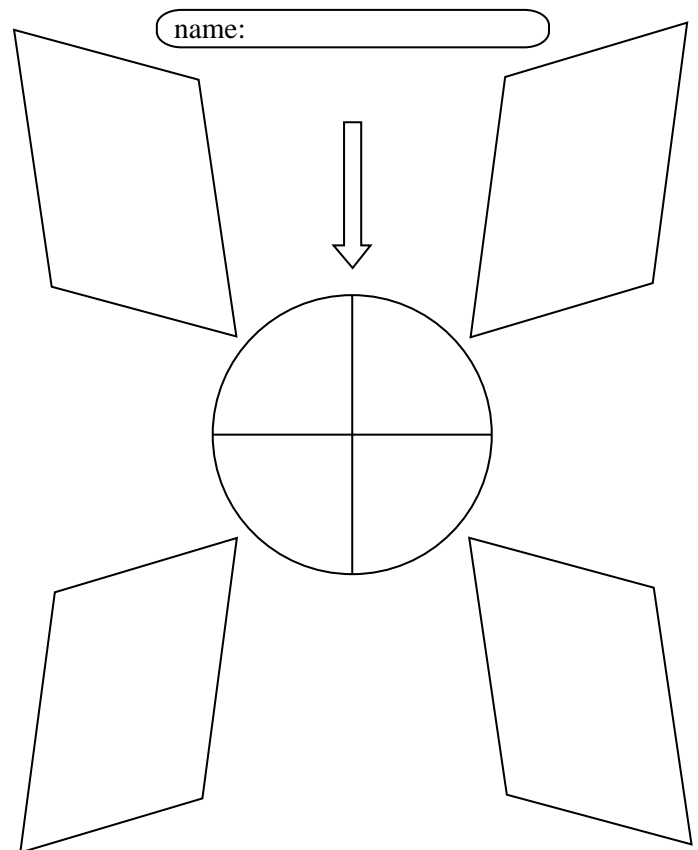
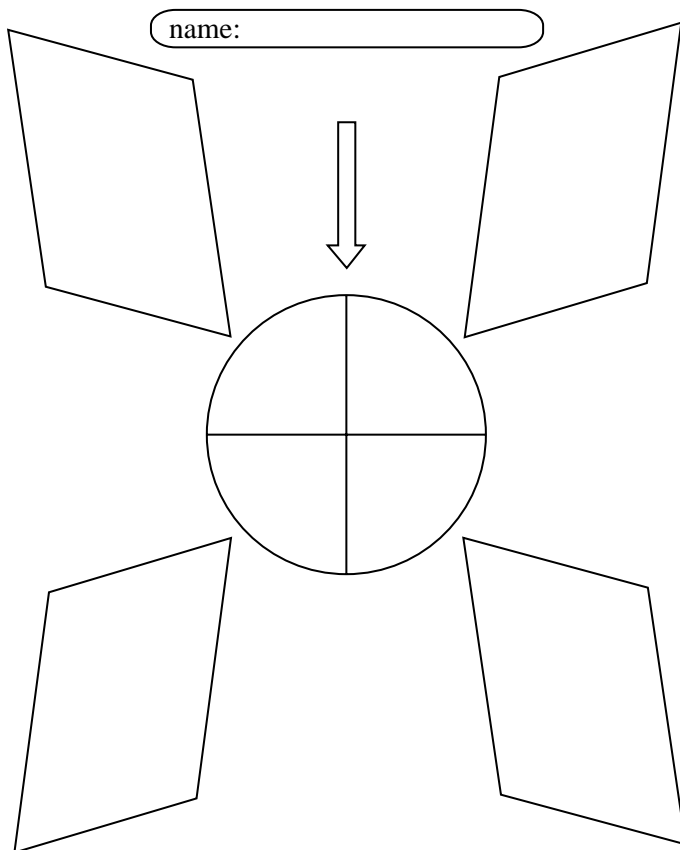

From book to film

Example: *Book: Forrest Gump by Winston Groom (Penguin Readers, Level 3)*
Film: 'Forrest Gump' starring Tom Hanks
Made in 1994 by Paramount Pictures

- 1 Read your book from the words 'The weeks went past slowly' on page 14 to the end of page 16.
- 2 Now look at these sentences from the section you have just read. In pairs, discuss these questions:
 - (a) Where do you think these things happened?
 - (b) If you were going to make a film of this scene, where would you shoot these events?

order of events in film

- (i) I also wrote a letter to Jenny Curran.
- (ii) Bubba and I decided that we would get a shrimp boat when we got home.
- (iii) It started to rain and didn't stop...
- (iv) But we still had to look for enemy soldiers and one day we found them.
- (v) I looked round for Bubba but he wasn't there.
- (vi) ...I saw another man who was hurt... so I picked him up ...
- (vii) Then I ran... and found Bubba.
- (viii) He said something very softly... and then he died.
- (ix) An American plane came and used fire throwers.

- 3 Watch the film clip. Tell your teacher to stop the film when you think each sentence above is being portrayed. Is it as you imagined or is it different? Number the events in the order in which they happen in the film.
- 4 Same or different?
 Are these sentences from the book the same or different in the film? Write S or D next to each one:
 - (i) Bubba planned it all.
 - (ii) It started to rain and didn't stop for two months.
 - (iii) We were crossing a rice field when suddenly they started shooting at us.
 - (iv) There was blood all over him and he had two bullets in his stomach.
 - (v) He looked up at me and said, 'Forrest, why did this happen?'
 - (vi) Somebody shot me in the back of the leg.
- 5 Read pages 14-16 of your book carefully again. Which parts have been omitted from the film? If you made the film, would you also leave these parts out?



Conversation: same or different?

- 1 Your teacher will dictate five sentences spoken by characters in your book. Write each sentence on the dotted lines below.
- 2 Can you remember who says the words, where, when and why? For each sentence, complete sections a) and b) in the table below.
- 3 Watch the film clip.
 - Are the words the same in the film as in the book? Tick the *same* or *different* boxes in section c) of the table.
 - If the words are different, what exactly do the characters say in the film? Write down the exact words.

1. '.....'

a) Speaker's name:	b) Where, when and why he/she spoke:
c) Words in the film: same <input type="checkbox"/>	different <input type="checkbox"/>
Exact words:	

2. '.....'

a) Speaker's name:	b) Where, when and why he/she spoke:
c) Words in the film: same <input type="checkbox"/>	different <input type="checkbox"/>
Exact words:	

3. '.....'

a) Speaker's name:	b) Where, when and why he/she spoke:
c) Words in the film: same <input type="checkbox"/>	different <input type="checkbox"/>
Exact words:	

4. '.....'

a) Speaker's name:	b) Where, when and why he/she spoke:
c) Words in the film: same <input type="checkbox"/>	different <input type="checkbox"/>
Exact words:	

5. '.....'

a) Speaker's name:	b) Where, when and why he/she spoke:
c) Words in the film: same <input type="checkbox"/>	different <input type="checkbox"/>
Exact words:	



Timelines: same or different?

Look at a short section of your book (one to three pages). Write the most important things that happen (events) on the 'book timeline' below. Then watch the corresponding part of the film and complete the 'film timeline':

BOOK TIMELINE

Event 1	
Event 2	
Event 3	
Event 4	
Event 5	
Event 6	
Event 7	
Event 8	
Event 9	
Event 10	

↓

FILM TIMELINE

Event 1	
Event 2	
Event 3	
Event 4	
Event 5	
Event 6	
Event 7	
Event 8	
Event 9	
Event 10	

↓

(add more boxes if you need them)

- When you have finished, draw lines which match events on the book timeline with the same events on the film timeline so that you can see what is the same and what is different.
- Discuss the screenwriter's reasons for:
 - a) differences in the order of events
 - b) differences in the events themselves.
- Which do you prefer – the book version or the film version?



Remembering the characters

Your teacher will show you some scenes from early parts of the film accompanying your book. Then choose two of the characters you have just seen and answer these questions.

Character 1

Name:

- What was the most important thing this person did in the story?
- Did you like or dislike this character? Why?
- What are this character's good points and bad points?
- Would you have behaved in the same way in the situation you have just seen?

Character 2

Name:

- What was the most important thing this person did in the story?
- Did you like or dislike this character? Why?
- What are this character's good points and bad points?
- Would you have behaved in the same way in the situation you have just seen?



Favourite scenes

Part A

- 1 Work in a small group. Make a list of all the scenes in the film that people in your group liked. Each person should suggest one or two of their favourite scenes.
- 2 Number these scenes in order of most to least preferred by the whole group.
- 3 Report back to the whole class.

Part B

Your teacher will show you one of the class's favourite scenes from the film.

- Watch this scene and then write notes on the topics below.
- Find the scene in the book, and complete the notes for the book version.

Setting

film

book

Characters

film

book

What happens

film

book

- In pairs, compare your answers and say whether you liked the film version or the book version best.



Book compared to film

Make notes in the table below:

	Book	Film
Setting (where does the story take place?)		
Main characters (names; their attitudes to each other; their character traits)		
Problem (what is the main problem that the story deals with?)		
Events (the main things that happen; how the characters try to resolve the problem(s))		
Climax (what happens to bring about the ending?)		
Ending		

- Did you prefer the book or the film?



A film review

You are going to write a film review. Answer these questions to help you plan your review:

- 1 Name of film.....
- 2 Film stars
- 3 Film director and producer (if known).....
- 4 Name of book
- 5 Author of book
- 6 What is this film about? Describe the story in three or four sentences.

- 7 What did you especially like or dislike about the film?

- 8 Is the film a good version of the book? Is it similar or very different?

- 9 What are your opinions of the actors?

- 10 Would you recommend the film? If so, what sort of people will like it?

- 11 Can you give the film an age rating?

- 12 And a star rating¹?

Find someone else and compare your answers. When you are ready, write your review.

¹ (***** = excellent, **** = very good, *** = good, ** = average, * = poor)



Penguin Longman Publishing

Pearson Education
80 Strand
London WC2R 0RL UK

© Pearson Education Limited 1999

Designed by Mackerel

All rights reserved: no part of this publication may be reproduced, stored in a retrieval system, or translated in any form or by any means, electronic, mechanical, photocopying, recording or otherwise, without the prior written permission of the publishers, with the sole exception of those pages marked 'photocopiable', which may be photocopied by teachers for classes they teach.

Published by Pearson Education Ltd. in association with Penguin Books Ltd., both companies being subsidiaries of Pearson plc.

ISBN 0 582 40008 2

Free Teacher's Resource Materials

The following additional free teacher's resource materials are available for use with Penguin Readers:

Penguin Readers Factsheets

Penguin Readers Factsheets have been developed for teachers using Penguin Readers with their class. Each factsheet is based on one Reader, and consists of:

- a summary of the book
- interesting information about the novel and novelist, including a section on the background and themes of the novel
- a glossary of new words
- a selection of lively supplementary activities for use with the Reader in class

Penguin Readers Factsheets are available to download free from our website www.penguinreaders.com

Penguin Readers Teacher's Guides

Penguin Readers Teacher's Guide to Using Graded Readers

ISBN 0 582 40006 6

Penguin Readers Teacher's Guide to Preparing for FCE

ISBN 0 582 40010 4

Penguin Readers Teacher's Guide to Developing Listening Skills

ISBN 0 582 34423 9

Penguin Readers Teacher's Guide to Using Bestsellers

ISBN 0 582 46900 7

Penguin Readers Teacher's Guide: Placement Tests

ISBN 0 582 47380 2

NB: Penguin Readers Factsheets and Penguin Readers Teacher's Guides contain photocopiable material.

www.penguindossiers.com

An innovative website offering new topical teaching articles every month - free of charge. Language is graded at Penguin Readers Level 3 and full teacher's notes are provided.

For a full list of Readers published in the Penguin Readers series, and for copies of the Penguin Longman catalogue, please contact your local Pearson Education office, or:

Elinor Garraway
Penguin Longman Publishing
Pearson Education
80 Strand
London WC2R 0RL UK
Tel: 0207 010 2810 Fax: 0207 010 6681
E-mail: elinor.garraway@pearsoned-ema.com

Visit our website at
www.penguinreaders.com





Penguin Readers

Teacher's Guide

to Using Film and TV

This guide offers English language teachers practical advice on how to use videos of feature films and TV series with Graded Readers. It contains a variety of suggestions for activities for use in the classroom, and includes 12 photocopiable student's worksheets. Some of the worksheets are linked to popular Penguin Readers, while others are general and can be used with any Graded Reader. All the worksheets can be easily adapted for use with a particular Graded Reader.

The guide describes:

- the role of Graded Readers in the learning of English and the main ways in which they can be used
- the advantages of using videos of feature films and TV series with graded Readers
- how the use of videos fits in with reading classes and the development of students' ability to read in English
- how to choose video material for use with Graded Readers
- a wide variety of activities and suggestions for using video clips with a class Reader:
 - before reading the book or sections of the book
 - after reading short sections of the book
 - after reading the book

The student's worksheets include the following activities:

- Establishing the characters
- Previewing a part of the book
- Getting the picture
- The starting point
- Thinking about character
- From book to film
- Conversation: same or different?
- Timelines: same or different?
- Remembering the characters
- Favourite scenes
- Book compared to film
- A film review

